

777-200

- Length : 63.7m
- Width : 60.9m
- 全長 : 63.7m
- 全幅 : 60.9m
- Maximum take-off weight : 201.8t
- Range : 4,740km
- 最大離陸重量 : 201.8t
- 航続距離 : 4,740km

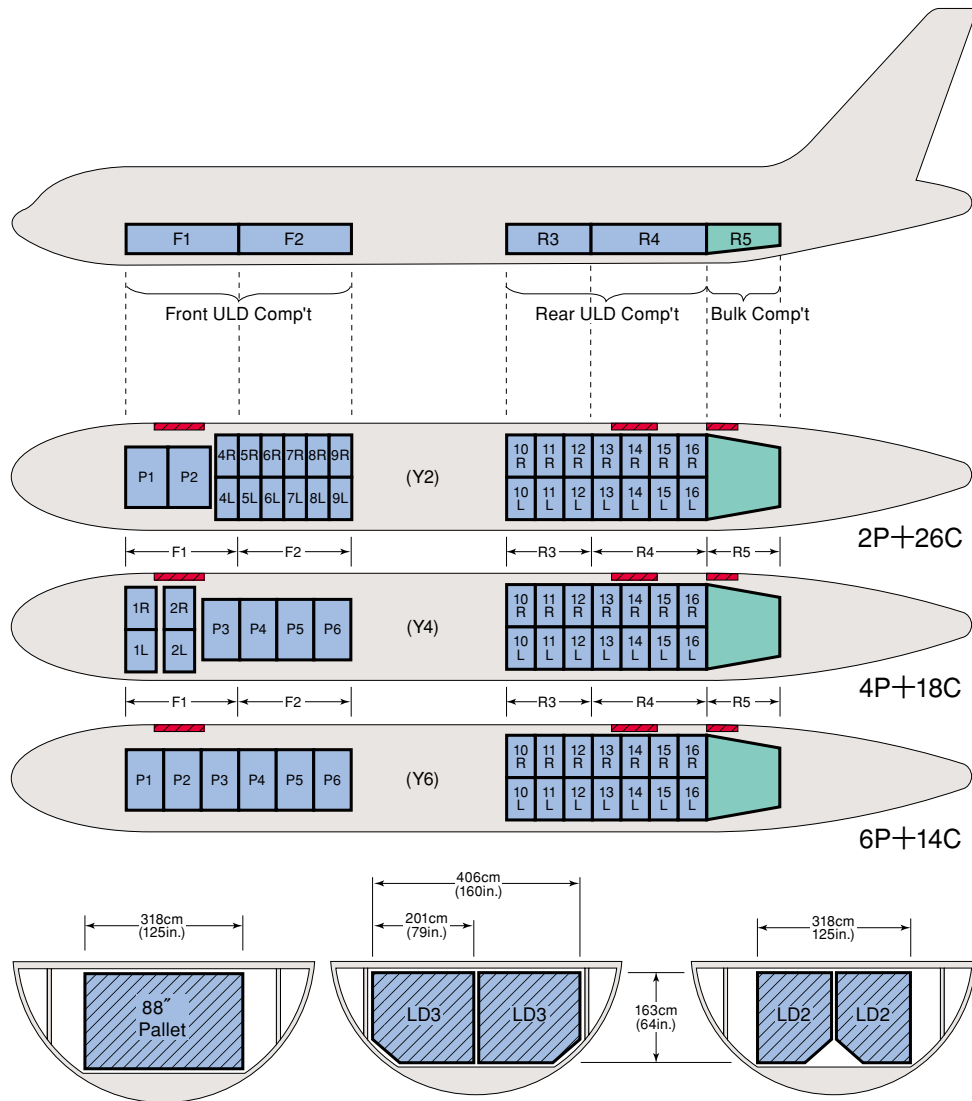

● Cargo Door Dimension ● Load Capacity and Temperature of Cargo Comp't

	Width×Height cm (in.)	Load Capacity		Temperature	
		kg (lb)	Switch	°C	°F
Front	269×170 (106× 67)	30,617 (67,500)	—	4~	40~
Rear	178×170 (70× 67)	22,226 (49,000)	High (Normal) Low	18~24 4~10	65~75 40~50
Bulk	91×114 (36× 45)	4,082 (9,000)	High (Normal) Low	18~24 4~10	65~75 40~50

注) 貨物室の温度は、あくまでも目安であり、保証されたものではありません。
Temperature is not guaranteed.

● Package Size Table (Bulk) cm (in.)

H	W					
	101 (40)	429 (169)	429 (169)	391 (154)	360 (142)	337 (133)
91 (36)	429 (169)	429 (169)	408 (161)	373 (147)	347 (137)	307 (121)
81 (32)	429 (169)	429 (169)	429 (169)	391 (154)	363 (143)	337 (133)
71 (28)	429 (169)	429 (169)	429 (169)	411 (162)	381 (150)	347 (137)
L	12 (5)	25 (10)	38 (15)	50 (20)	63 (25)	84 (33.2)

● Bulk Comp't Dimension

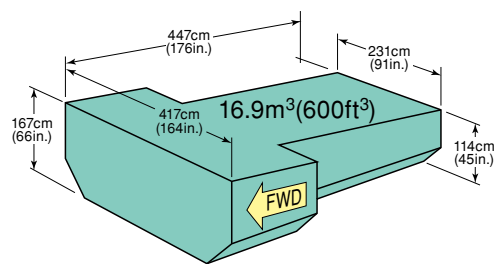

777-200ER

- Length : 63.7m
- Width : 60.9m
- 全長 : 63.7m
- 全幅 : 60.9m
- Maximum take-off weight : 294.8t
- Range : 12,600km
- 最大離陸重量 : 294.8t
- 航続距離 : 12,600km

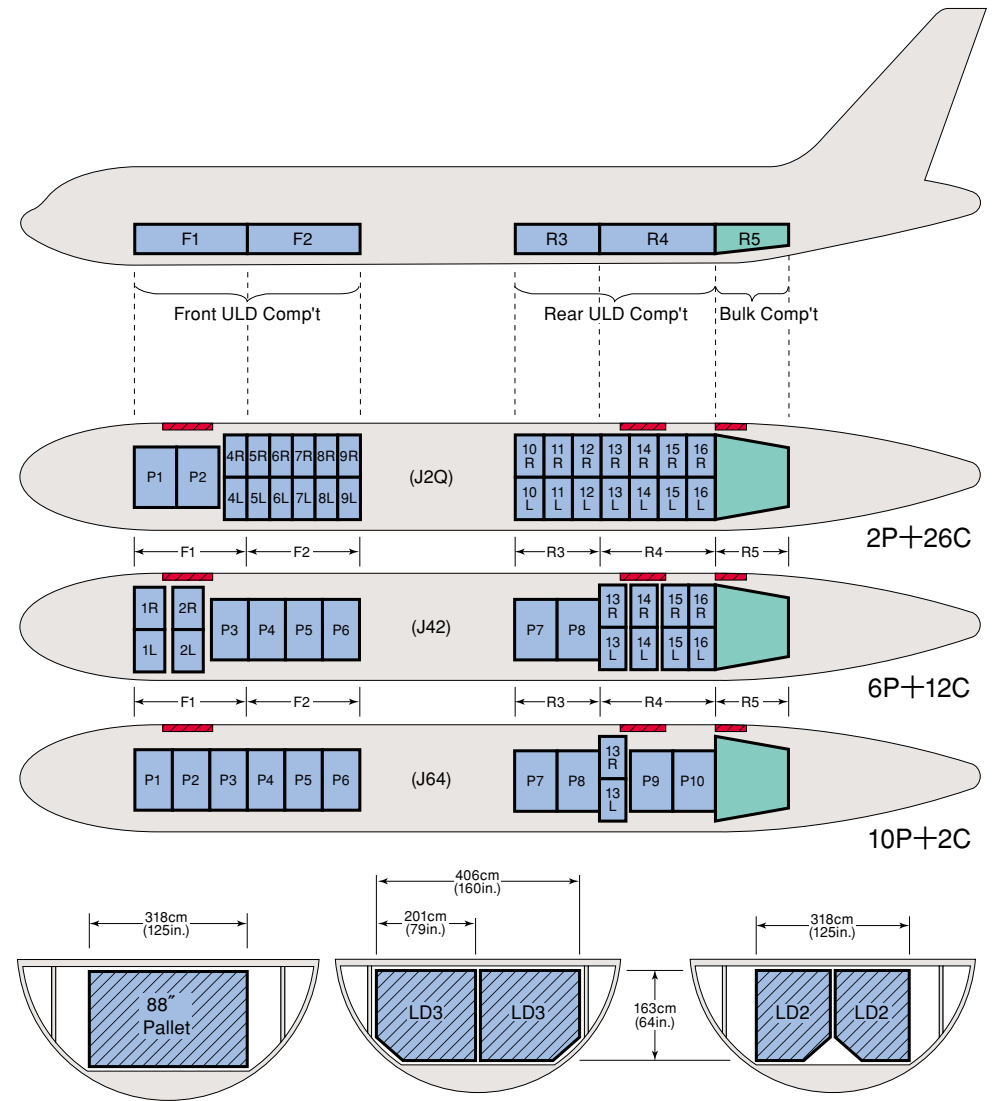

● Cargo Door Dimension ● Load Capacity and Temperature of Cargo Comp't

	Width×Height cm (in.)	Load Capacity		Temperature	
		kg (lb)	Switch	°C	°F
Front	269×170 (106× 67)	30,617 (67,500)	—	4~	40~
Rear	269×170 (106× 67)	22,226 (49,000)	High (Normal) Low	18~24 4~10	65~75 40~50
Bulk	91×114 (36× 45)	4,082 (9,000)	High (Normal) Low	18~24 4~10	65~75 40~50

注) 貨物室の温度は、あくまでも目安であり、保証されたものではありません。
Temperature is not guaranteed.

● Package Size Table (Bulk) cm (in.)

H	W					
	101 (40)	429 (169)	429 (169)	391 (154)	360 (142)	337 (133)
91 (36)	429 (169)	429 (169)	408 (161)	373 (147)	347 (137)	307 (121)
81 (32)	429 (169)	429 (169)	429 (169)	391 (154)	363 (143)	337 (133)
71 (28)	429 (169)	429 (169)	429 (169)	411 (162)	381 (150)	347 (137)
L	12 (5)	25 (10)	38 (15)	50 (20)	63 (25)	84 (33.2)

● Bulk Comp't Dimension

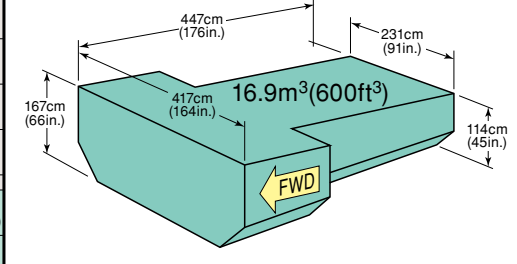

777-300/300ER

- Length : 73.9m
- Width : 60.9m
- 全長 : 73.9m
- 全幅 : 60.9m
- Maximum take-off weight : 339.8t
- Range : 12,000km
- 最大離陸重量 : 339.8t
- 航続距離 : 12,000km



767-300/300L/300ER

- Length : 54.9m
- Width : 47.6m
- 全長 : 54.9m
- 全幅 : 47.6m
- Maximum take-off weight : 182.1t
- Range : 9,400km
- 最大離陸重量 : 182.1t
- 航続距離 : 9,400km

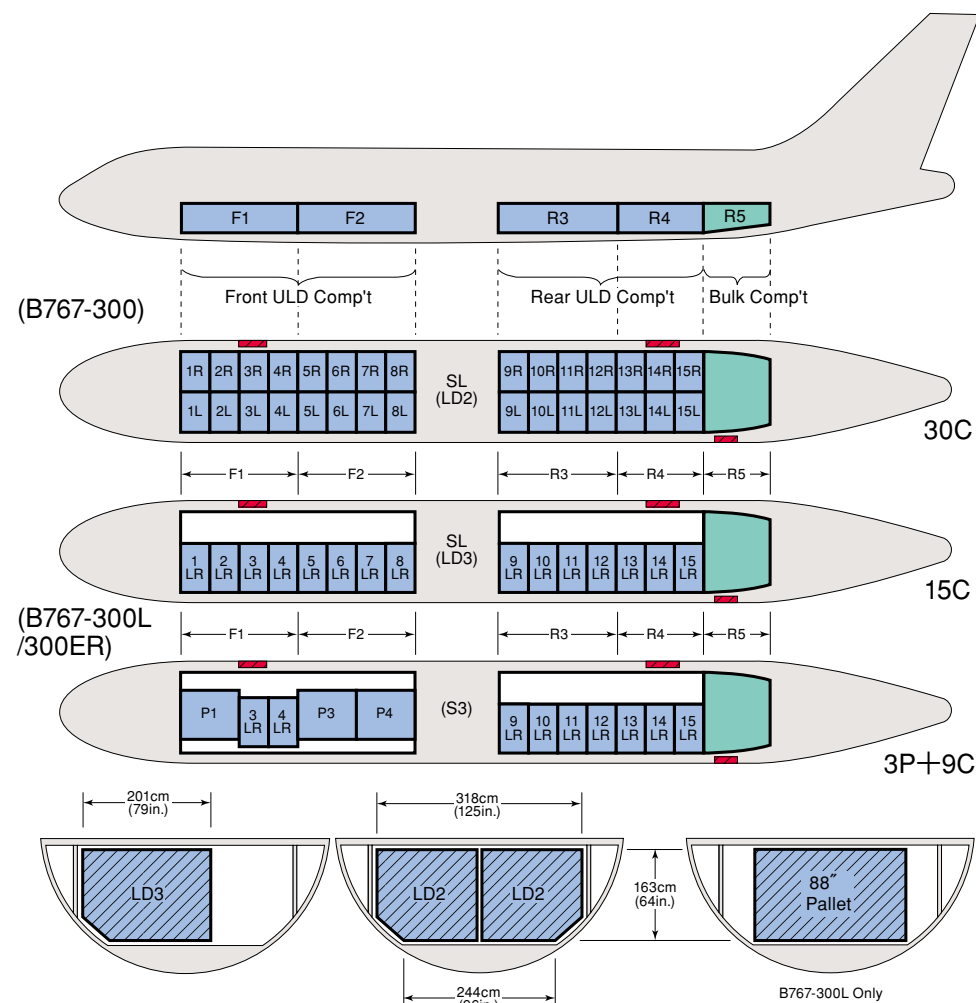
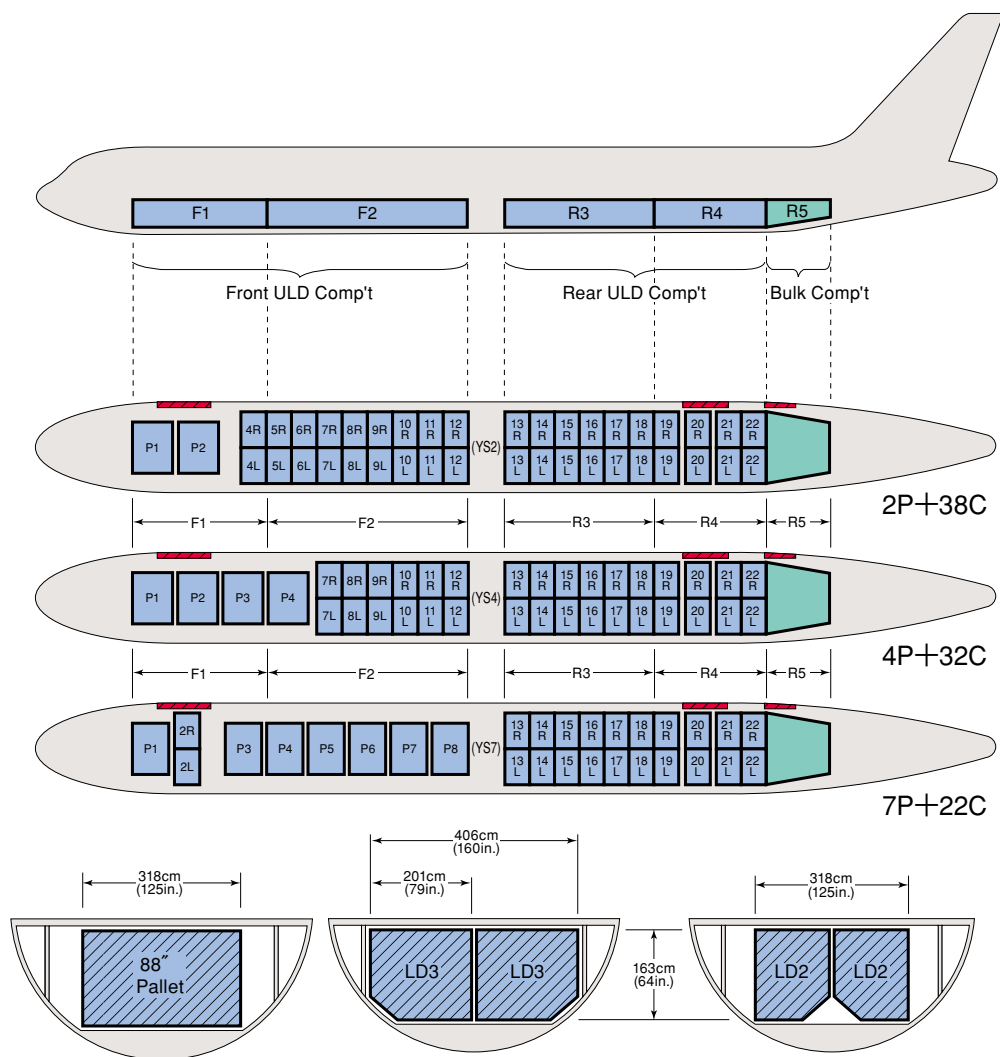

● Cargo Door Dimension

	Width×Height cm (in.)
Front	269×170 (106× 67)
Rear	178×170 (70× 67)
Bulk	91×114 (36× 45)

● Load Capacity and Temperature of Cargo Comp't

	Load Capacity kg (lb)	Temperature		
		Switch	°C	°F
Front	40,820 (90,000)	—	4~	40~
Rear	31,749 (70,000)	High (Normal) Low	18~24 4~10	65~75 40~50
Bulk	4,082 (9,000)	High (Normal) Low	18~24 4~10	65~75 40~50

注) 貨物室の温度は、あくまでも目安であり、保証されたものではありません。
Temperature is not guaranteed.

● Package Size Table (Bulk)

H	cm (in.)						
	101 (40)	429 (169)	429 (169)	391 (154)	360 (142)	337 (133)	312 (123)
91 (36)	429 (169)	429 (169)	408 (161)	373 (147)	347 (137)	307 (121)	
81 (32)	429 (169)	429 (169)	429 (169)	391 (154)	363 (143)	337 (133)	
71 (28)	429 (169)	429 (169)	429 (169)	411 (162)	381 (150)	347 (137)	
L	W						
	12 (5)	25 (10)	38 (15)	50 (20)	63 (25)	84 (33.2)	

● Bulk Comp't Dimension

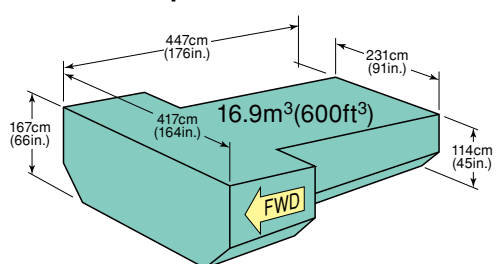

● Cargo Door Dimension

	Width×Height cm (in.)	
	300	300L/300ER
Front	178×167 (70× 66)	340×167 (134× 66)
Rear	178×167 (70× 66)	
Bulk	97×110 (38×43.5)	

● Load Capacity and Temperature of Cargo Comp't

	Load Capacity kg (lb)	Temperature		
		Switch	°C	°F
Front	(F1) 9,797 (21,600) (F2) 9,797 (21,600)	—	4~10	40~50
Rear	(R3) 9,797 (21,600) (R4) 7,348 (16,200)	—	4~10	40~50
Bulk	2,925 (6,450)	Normal Vent	10~16 18~24	50~60 65~75

注) 貨物室の温度は、あくまでも目安であり、保証されたものではありません。
Temperature is not guaranteed.

● Package Size Table (Bulk)

H	cm (in.)						
	119 (47.2)	302 (119)					
118 (46.6)	302 (119)	302 (119)					
115 (45.5)	302 (119)	302 (119)	302 (119)				
106 (42.0)	302 (119)	302 (119)	302 (119)	302 (119)	302 (119)		
90 (35.7)	302 (119)	302 (119)	302 (119)	302 (119)	302 (119)		
50 (20.0)	302 (119)	302 (119)	302 (119)	302 (119)	302 (119)	302 (119)	
25 (10.0)	302 (119)	302 (119)	302 (119)	302 (119)	302 (119)	302 (119)	
12 (5.0)	302 (119)	302 (119)	302 (119)	302 (119)	302 (119)	302 (119)	302 (119)
L	W						
	12 (5)	25 (10)	50 (20)	76 (30)	88 (35)	91 (36)	93 (36.6)

● Bulk Comp't Dimension

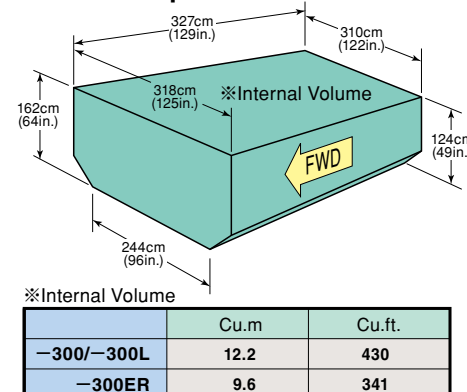

	Cu.m	Cu.ft.
-300/-300L	12.2	430
-300ER	9.6	341

737-400

- Length : 36.4m
- Width : 28.9m
- 全長 : 36.4m
- 全幅 : 28.9m
- Maximum take-off weight : 62.8t
- Range : 3,320km
- 最大離陸重量 : 62.8t
- 航続距離 : 3,320km

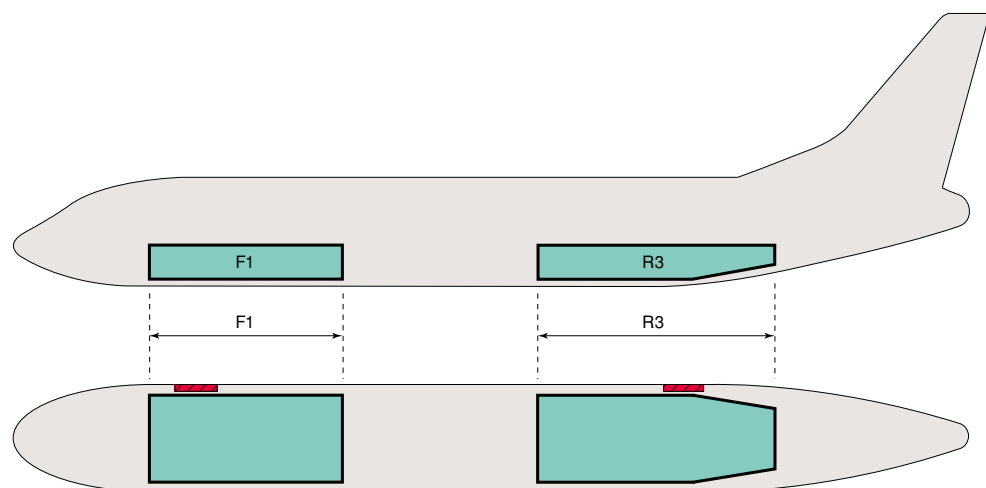

Bulk Only

Front Comp't Dimension

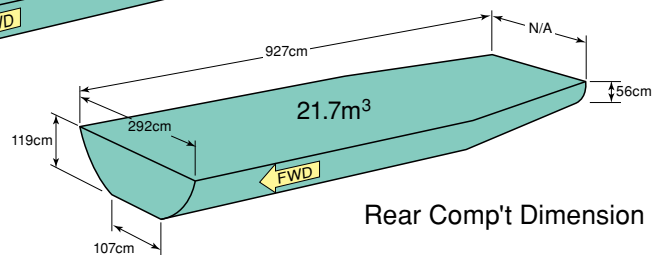
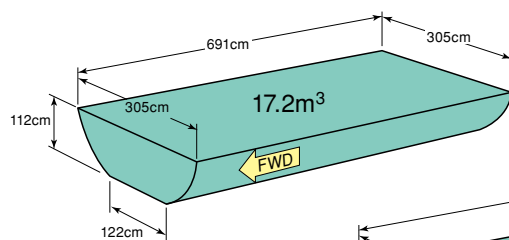

Rear Comp't Dimension

● Cargo Door Dimension ● Load Capacity and Temperature of Cargo Comp't

	Width×Height cm
Front	122×89
Rear	122×84

	Load Capacity	Temperature		
	kg	Switch	°C	°F
Front	3,240	—	4.4~	40~
Rear	3,958	—	0~	32~

注) 貨物室の温度は、あくまでも目安であり、保証されたものではありません。
Temperature is not guaranteed.

● Package Size Table (Front) cm

H	86	327	302	251	200	175	152	137
	76	330	302	251	200	175	152	137
	66	330	302	251	200	175	152	137
	55	335	302	251	200	175	152	137
	45	340	304	251	200	175	152	137
	35	347	307	251	200	175	152	137
	25	363	314	251	200	175	152	137
	12	401	332	251	200	175	152	137
	L		12	25	50	76	88	101

● Package Size Table (Rear) cm

H	86	350	320	266	215	190	165	147
	76	353	320	266	215	190	165	147
	66	358	320	266	215	190	165	147
	55	363	325	266	215	190	165	147
	45	373	327	266	215	190	165	147
	35	391	335	266	215	190	165	147
	25	416	350	269	215	190	165	147
	12	487	386	276	215	190	165	147
	L		12	25	50	76	88	101

737-800

- Length : 39.5m
- Width : 35.8m
- 全長 : 39.5m
- 全幅 : 35.8m
- Maximum take-off weight : 70.5t
- Range : 4,500km
- 最大離陸重量 : 70.5t
- 航続距離 : 4,500km

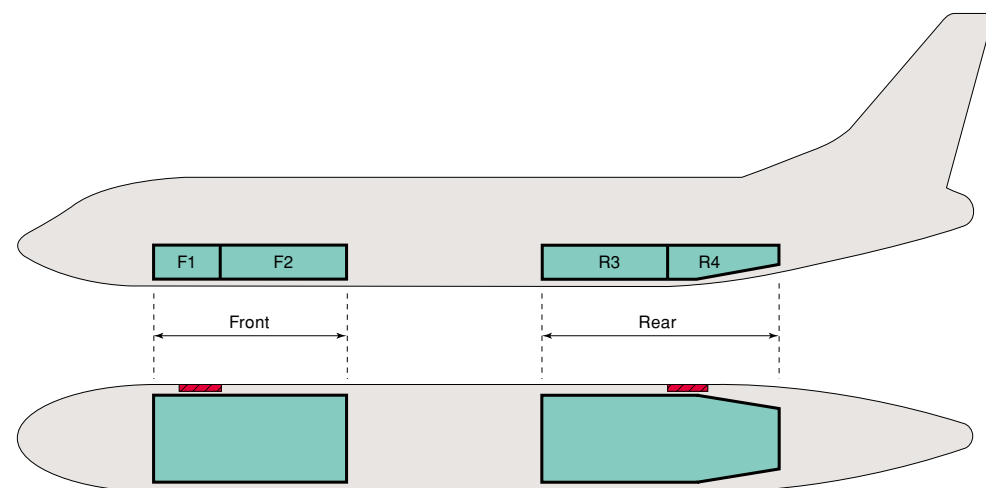

Bulk Only

Front Comp't Dimension

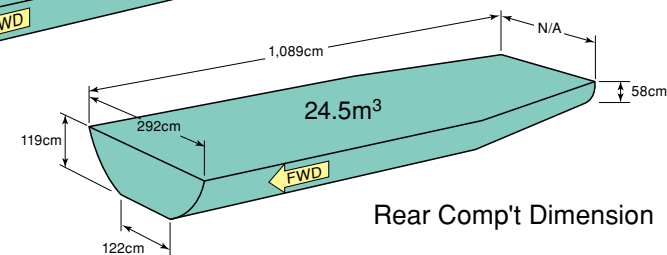
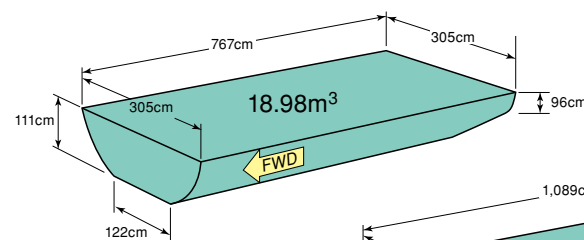

Rear Comp't Dimension

● Cargo Door Dimension ● Load Capacity and Temperature of Cargo Comp't

	Width×Height cm
Front	122×89
Rear	122×84

	Load Capacity	Temperature		
	kg	Switch	°C	°F
Front	(F1) 888 (F2) 2,449	—	5~10 以上	40~50 以上
Rear	(R3) 3,826 (R4) 764	—	5~10 以上	40~50 以上

注) 貨物室の温度は、あくまでも目安であり、保証されたものではありません。
Temperature is not guaranteed.

● Package Size Table (Front) cm

H	86	314	289	238	187	162	137	127
	76	314	289	238	187	162	137	127
	66	314	289	238	187	162	137	127
	55	314	289	238	187	162	137	127
	45	317	289	238	187	162	137	127
	35	322	289	238	187	162	137	127
	25	332	294	238	187	162	137	127
	12	396	304	238	187	162	137	127
	L		12	25	50	76	88	101

● Package Size Table (Rear) cm

H	86	177	152					
	76	309	284	233	182	157	132	109
	66	309	284	233	182	157	132	109
	55	309	284	233	182	157	132	109
	45	314	284	233	182	157	132	109
	35	322	284	233	182	157	132	109
	25	350	297	233	182	157	132	109
	12	416	330	233	182	157	132	109
	L		12	25	50	76	88	101

MD-90

- Length : 46.5m
- Width : 32.9m
- 全長 : 46.5m
- 全幅 : 32.9m
- Maximum take-off weight : 70.8t
- Range : 2,330km
- 最大離陸重量 : 70.8t
- 航続距離 : 2,330km

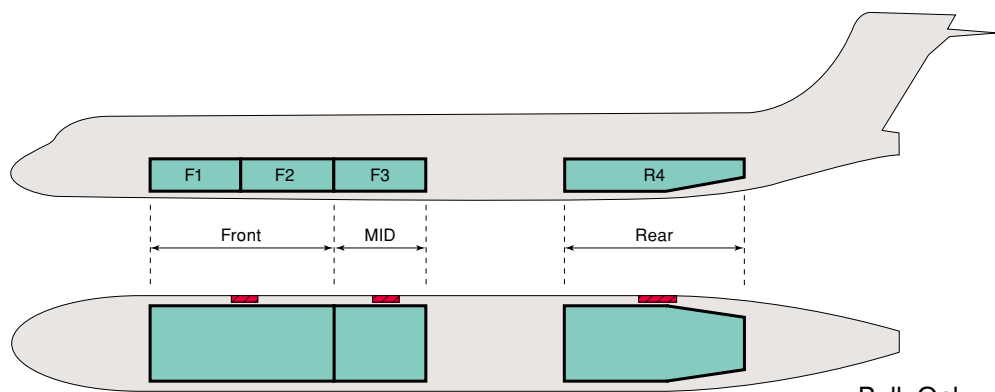

Bulk Only

Front Comp't Dimension

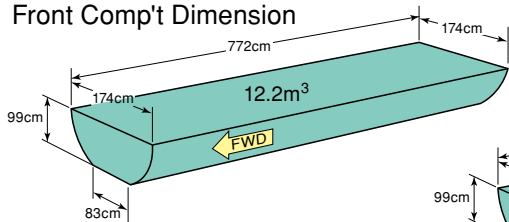

MID Comp't Dimension

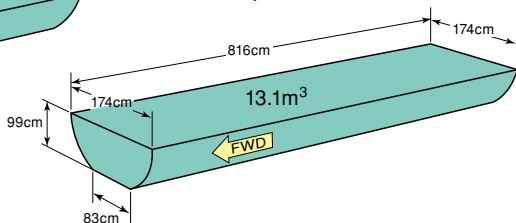

Rear Comp't Dimension

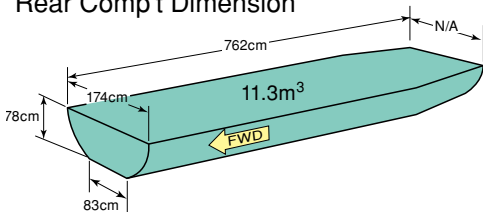

● Cargo Door Dimension

	Width×Height cm
Front	134×75
MID	
Rear	

● Package Size Table (Front)

H	cm														
	73	60	45	30	15	7	411	388	365	312	271	238	205	172	127
L	7	15	30	45	60	76	91	106	132						
	W														

● Load Capacity and Temperature of Cargo Comp't

	Load Capacity kg	Temperature		
		Switch	°C	°F
Front	(F1) 1,626 (F2) 1,326	—	15.6~23.9	60~75
MID	4,227	—	—	—
Rear	2,721	—	—	—

注) 貨物室の温度は、あくまでも目安であり、保証されたものではありません。
Temperature is not guaranteed.

● Package Size Table (MID)

H	cm														
	73	60	45	30	15	7	431	401	365	312	271	238	205	172	127
L	7	15	30	45	60	76	91	106	132						
	W														

● Package Size Table (Rear)

H	cm														
	73	60	45	30	15	7	330	304	236	236	236	205	172	127	
L	7	15	30	45	60	76	91	106	132						
	W														

EMBRAER170

- Length : 29.9m
- Width : 26.0m
- 全長 : 29.9m
- 全幅 : 26.0m
- Maximum take-off weight : 34.5t
- Range : 3,100km
- 最大離陸重量 : 34.5t
- 航続距離 : 3,100km

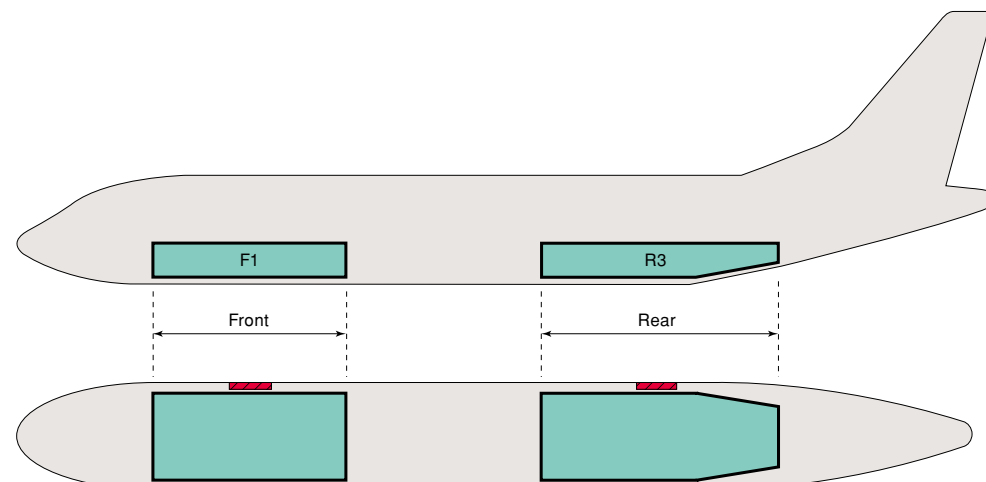

Bulk Only

Front Comp't Dimension

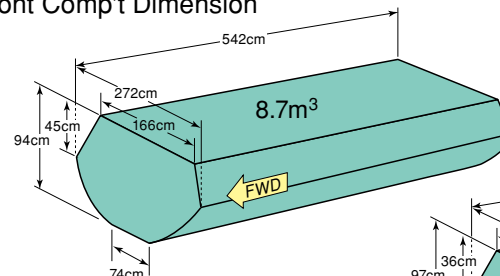

Rear Comp't Dimension

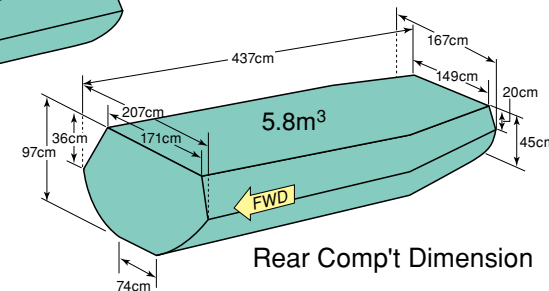

● Cargo Door Dimension

	Width×Height cm
Front	110×90
Rear	99×(78~87)

● Load Capacity and Temperature of Cargo Comp't

	Load Capacity kg	Temperature		
		Switch	°C	°F
Front	1,370	—	about 25	about 77
Rear	1,030	—	—	—

注) 貨物室の温度は、あくまでも目安であり、保証されたものではありません。
Temperature is not guaranteed.

● Package Size Table (Front)

H	cm									
	12	20	25	33	40	48	55	63	71	
L	12	25	38	50	63	76	88	101		
	W									

● Package Size Table (Rear)

H	cm								
	12	25	38	50	63	76	88	101	
L	12	25	38	50	63	76	88	101	
	W								

SAAB340B

- Length : 19.7m
- Width : 21.4m
- 全長 : 19.7m
- 全幅 : 21.4m
- Maximum take-off weight : 12.9t
- Range : 1,810km
- 最大離陸重量 : 12.9t
- 航続距離 : 1,810km

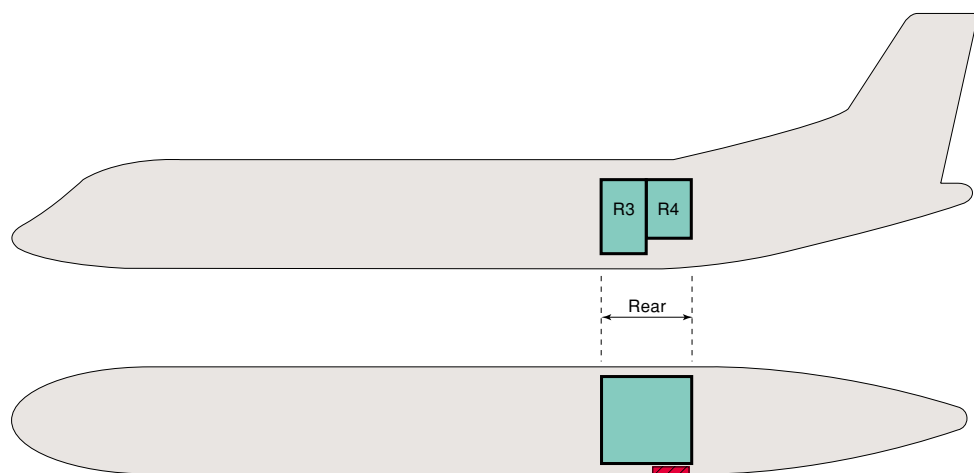

Bulk Only

● Cargo Door Dimension

	Width×Height cm
Rear	135×130

● Load Capacity and Temperature of Cargo Comp't

	Load Capacity		Temperature		
	kg	Vol	Switch	°C	°F
Rear	(R3) 510 (Not TIED DOWN)	3.3m ³	—	N/A	N/A
	680 (TIED DOWN)				
(R4)	385	3.5m ³	—	—	—

注) 貨物室の温度は、あくまでも目安であり、保証されたものではありません。
Temperature is not guaranteed.

● Package Size Table (R3)

H	cm								
	127	147	147	147	147	135	—	—	—
102	147	147	147	147	135	—	—	—	—
76	147	147	147	147	135	—	—	—	—
51	147	147	147	147	135	—	—	—	—
25	147	147	147	147	135	—	—	—	—
L	W								
	25	38	51	63	76	89	102	114	—

● Package Size Table (R4)

H	cm								
	127	147	147	142	137	122	114	—	—
102	147	147	142	137	122	114	—	—	—
76	147	147	142	137	122	114	—	—	—
51	168	160	152	150	137	132	117	—	—
25	168	160	152	150	137	132	117	—	—
L	W								
	25	38	51	63	76	89	102	114	—

● Package Size Table (R3+R4)

H	cm								
	127	218	218	183	178	165	140	—	—
102	218	218	183	178	165	140	—	—	—
76	218	218	183	178	165	140	—	—	—
51	249	239	198	180	175	170	157	—	—
25	249	239	198	180	175	170	157	—	—
L	W								
	25	38	51	63	76	89	102	114	—

DASH8-400(Q400)

- Length : 32.8m
- Width : 28.4m
- 全長 : 32.8m
- 全幅 : 28.4m
- Maximum take-off weight : 28.0t
- Range : 2,146km
- 最大離陸重量 : 28.0t
- 航続距離 : 2,146km

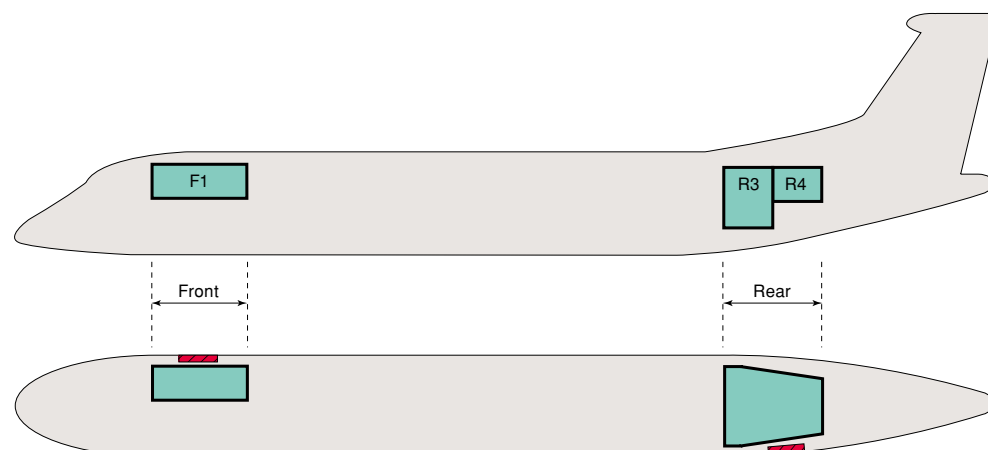

Bulk Only

● Cargo Door Dimension

	Width×Height cm
Front	50×148
Rear	127×143

● Load Capacity and Temperature of Cargo Comp't

	Load Capacity		Temperature		
	kg	vol	Switch	°C	°F
Front	430	2.5m ³	—	18~27	65~80
Rear	(R3) 1,710 (R4) 454	7.9m ³ 3.4m ³	—		

注) 貨物室の温度は、あくまでも目安であり、保証されたものではありません。
Temperature is not guaranteed.

● Package Size Table (Front)

H	cm					
	137	71	69	66	64	56
122	81	76	71	66	66	58
107	91	86	76	66	66	58
91	99	94	81	69	61	61
76	109	102	86	71	61	61
61	119	109	94	74	64	64
46	130	119	99	74	66	66
30	137	127	104	76	66	66
15	147	135	109	79	69	69
8	152	140	112	79	69	69
L	W					
	8	15	30	46	61	—

● Package Size Table (Rear/R3)

H	cm									
	152	117	114	112	—	—	—	—	—	—
137	145	145	145	140	137	132	—	—	—	—
122	150	150	150	147	142	137	—	—	—	—
107	191	183	170	155	152	150	147	145	140	—
91	191	183	170	155	152	150	147	145	140	—
76	210	205	195	185	183	183	183	183	183	—
61	210	205	195	185	183	183	183	183	183	—
46	210	205	195	185	183	183	183	183	183	—
30	210	205	195	185	183	183	183	183	183	—
15	210	205	195	185	183	183	183	183	183	—
8	210	205	195	185	183	183	183	183	183	—
L	W									
	8	15	30	46	61	76	91	107	122	—

● Package Size Table (Rear/R4)

H	cm								
	152	84	84	84	—	—	—	—	—
137	84	84	84	84	84	84	—	—	—
122	114	106	90	84	84	84	—	—	—
107	114	106	90	84	84	84	84	84	84
91	114	106	90	84	84	84	84	84	84
76	114	106	90	84	84	84	84	84	84
61	114	106	90	84	84	84	84	84	84
46	114	106	90	84	84	84	84	84	84
30	114	106	90	84	84	84	84	84	84
15	114	106	90	84	84	84	84	84	84
8	114	106	90	84	84	84	84	84	84
L	W								
	8	15	30	46	61	76	91	107	122

● Package Size Table (Rear/R3+R4)

H	cm									
	152	114	114	112	—	—	—	—	—	—
137	145	145	145	140	137	132	—	—	—	—
122	150	150	150	147	142	137	—	—	—	—
107	191	183	170	155	152	150	147	145	140	—
91	191	183	170	155	152	150	147	145	140	—
76	292	287	274	264	254	246	241	224	201	—
61	292	287	277	264	257	249	241	226	203	—
46	292	290	277	267	257	249	244	226	203	—
30	295	290	277	267	259	251	246	229	203	—
15	297	290	279	269	259	251	246	231	203	—
8	297	292	279	269	259	251	246	231	203	—
L	W									
	8	15	30	46	61	76	91	107	122	—

CRJ-200

- Length : 26.8m
- Width : 21.2m
- 全長 : 26.8m
- 全幅 : 21.2m
- Maximum take-off weight : 23.1t
- Range : 3,045km
- 最大離陸重量 : 23.1t
- 航続距離 : 3,045km

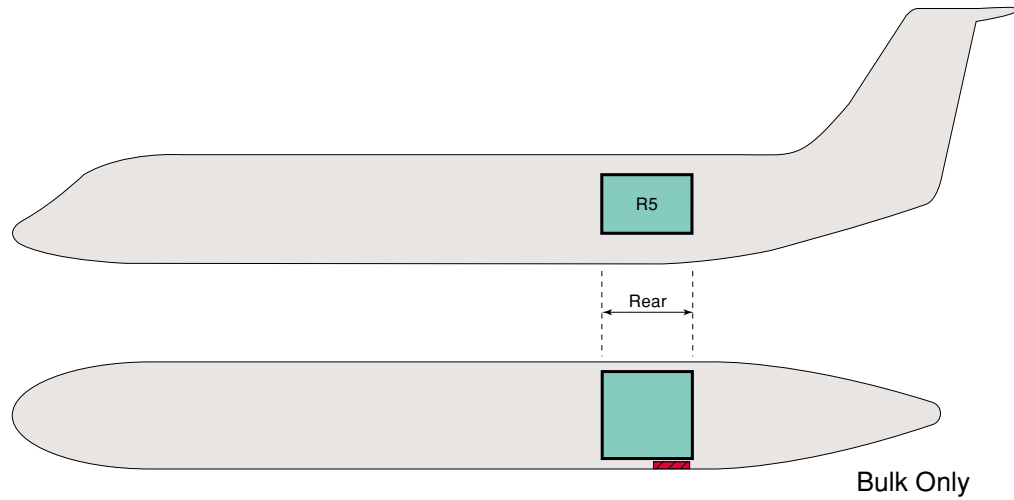

Bulk Only

● Cargo Door Dimension

	Width×Height cm
Rear	109×83

● Load Capacity and Temperature of Cargo Comp't

	Load Capacity		Temperature		
	kg	Vol	Switch	°C	°F
Rear	1588	8.9m ³	COND AIR	21~27	70~81
			FAN	0~	32~
			OFF	—	—

注) 貨物室の温度は、あくまでも目安であり、保証されたものではありません。
Temperature is not guaranteed.

PALLET

● UNIT LOAD DEVICES (ULD)

下記重量は最大値であり、搭載位置により制限がかかります。

Base Size	IATA I.D. Code (ATA Code)	Illustration イラスト	Int Volume 内容量:m ³ (ft ³)		Tare Wt 自重:kg (lb) *including NET WT		
			External Dimension 外寸 cm (in)	Internal Dimension 内寸 cm (in)	Loadable Aircraft & Comp't 搭載可能 機種&貨物室	Weight Limitation Inc ULD Tare Wt 重量制限 含 自重 kg (lb)	
ULD Type For UDC							
88" X125"	PAG IC DC		—		108 (238) ~ 134 (295)		
			L	317 (125)	294 (116)	767 LD 777 LD	5102 (11250) 5102 (11250)
			W	223 (88)	200 (88)		
			H	162 (64)			
			5				
88" X125"	XAU IC		—		176 (388)		
			L	317 (125)	287 (113)	777 LD	5102 (11250)
			L'	391 (154)			
			W	223 (88)	193 (76)		
			162 (64)				
96" X125"	PMC PMZ IC DC		—		132 (291) ~ 140 (309)		
			L	317 (125)	294 (116)	767 LD 777 LD	5102 (11250) 6350 (14000)
			W	243 (96)	220 (87)		
			H	162 (64)			
			2BG				

NOTE 777:777 767:767 IC: International Line Use DC: Domestic Line Use LD: Lower Deck
1 in=2.54cm 1 ft³=0.0283m³ 1 lb=0.4536kg

CONTAINER

下記重量は最大値であり、搭載位置により制限がかかります。

Base Size	IATA I.D. Code (ATA Code)	Illustration イラスト	Int Volume 内容量:m ³ (ft ³)		Tare Wt 自重:kg (lb) *Including NET WT	
			L External Dimension 外寸 cm (in)	Internal Dimension 内寸 cm (in)	Loadable Aircraft & Comp't 搭載可能 機種&貨物室	Weight Limitation Inc ULD Tare Wt 重量制限 含 自重 kg (lb)

60.4" X 47"	DPN (LD-2)		3.2(113)~3.7(131)		91(201)~98(216)		
			L	119(47)	109(43)	767 LD 1224(2700)	777 LD 1224(2700)
			L'	157(62)	147(58)		
			W	152(60)	139(55)		
			H	162(64)	142(56)		
DC		---		---			

60.4" X 96"	DQF (LD-8)		7.1(251)		140(309)~150(330)		
			L	243(96)	233(92)	767 LD 2449(5400)	---
			L'	317(125)	312(123)		
			W	152(60)	139(55)		
			H	162(64)	154(61)		
IC DC		6A		---			

60.4" X 61.5"	AKE (LD-3)		3.9(138)~4.4(155)		85(187)~118(260)		
			L	157(62)	147(58)	767 LD 1587(3500)	777 LD 1587(3500)
			L'	200(79)	190(75)		
			W	152(60)	139(55)		
			H	162(64)	157(62)		
IC		GARMENT TYPE AVAILABLE		8			

60.4" X 125"	AKN DKN DVN (LD-3)		3.9(138)~4.1(145)		102(226)~138(304)		
			L	157(62)	149(59)	767 LD 1587(3500)	777 LD 1587(3500)
			L'	200(79)	190(75)		
			W	152(60)	139(55)		
			H	162(64)	142(56)		
IC DC		GARMENT TYPE AVAILABLE		---			

60.4" X 125"	ALF DLF (LD-6)		8.9(314)		191(421)~197(433)		
			L	317(125)	304(120)	777 LD 3175(7000)	---
			L'	406(160)	398(157)		
			W	152(60)	139(55)		
			H	162(64)	154(61)		
IC DC		6		---			

NOTE 777:777 767:767

下記重量は最大値であり、搭載位置により制限がかかります。

Base Size	IATA I.D. Code (ATA Code)	Illustration イラスト	Int Volume 内容量:m ³ (ft ³)		Tare Wt 自重:kg (lb) *Including NET WT	
			L External Dimension 外寸 cm (in)	Internal Dimension 内寸 cm (in)	Loadable Aircraft & Comp't 搭載可能 機種&貨物室	Weight Limitation Inc ULD Tare Wt 重量制限 含 自重 kg (lb)

60.4" X 125"	ALP AWB (LD-11)		8.9(314)		164(362)~191(421)		
			L	317(125)	299(118)	777 LD 3175(7000)	---
			W	152(60)	144(57)		
			H	162(64)	160(63)		
			DC		6		

88" X 125"	AAP (LD-7)		10.4(367)		214(472)~311(684)		
			L	317(125)	292(115)	767 LD 5102(11250)	777 LD 5102(11250)
			W	223(88)	200(79)		
			H	162(64)	154(61)		
			IC DC		GARMENT TYPE FORKLIFTABLE AVAILABLE		

88" X 125"	AAF DAF (LD-26)		12.5(441)		280(617)		
			L	317(125)	299(118)	777 LD 5102(11250)	---
			L'	406(160)	396(156)		
			W	223(88)	203(80)		
			H	162(64)	154(61)		
IC DC		---		---			

NOTE 777:777 767:767

● 国内線専用ULD (ULD for Japan domestic service only)

I.D. Code	Illustration イラスト	Int Volume 内容量:m ³ (ft ³)		Loadable ULD 搭載可能ULD	Loadable Weight 搭載可能重量 kg (lb)
		L External Dimension 外寸 cm	Internal Dimension 内寸 cm		

XTNA		1.4(49)		88" X 125" パレット	1200(2650)
		L	202		
		W	152	137	(1) Tuna Container ツナコンテナ (2) 88" X 125" N パレット用 (3) 2段積み可
		H	75	55	
		---		160(353)	

SPECIAL ULD

● 保冷コンテナ (Refrigerated ULD)

下記重量は最大値であり、搭載位置により制限がかかります。

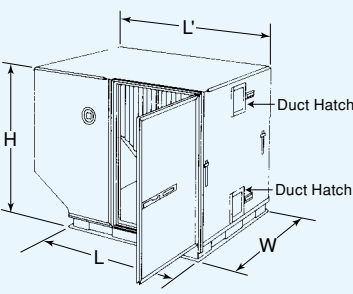
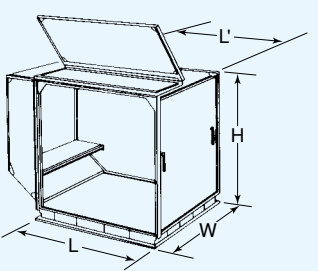
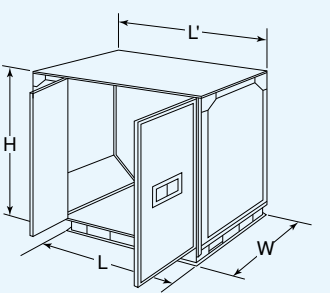
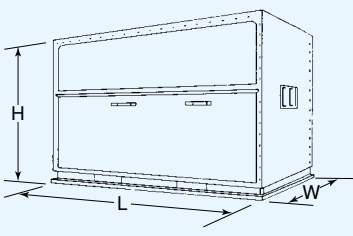
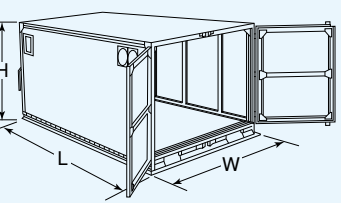
Base Size	IATA I.D. Code (ATA Code)	Illustration イラスト	Int Volume 内容量:m ³ (ft ³)		Loadable Aircraft & Comp't 搭載可能 機種&貨物室	Weight Limitation Inc ULD Tare Wt 重量制限 含 自重 kg (lb)	
			External Dimension 外寸 cm (in)	Internal Dimension 内寸 cm (in)			
	国際 IC	国内 DC	Tare Wt 自重:kg (lb) *Including NET WT		Capability 性能諸元		
60.4" X 61.5"	MVN (LD-3)		3.7 (131)		See DKN/DVN	(1) Thermal Insulated 保冷 (2) No Temp Control 温度管理不可 (3) Coolant: COOL AIR/DRY ICE 冷風ユニット使用	
			L	157 (62)			132 (52)
			L'	200 (79)			177 (70)
			W	152 (60)			129 (51)
			H	160 (63)	132 (52)		
			320 (705)				
60.4" X 61.5"	MKN MKNK (LD-3)		3.8 (134)		See DKN/DVN	(1) Thermal Insulated by Polystyrene panel at the inside surface 簡易保冷 (2) No Temp Control 温度管理不可	
			L	157 (62)			137 (54)
			L'	200 (79)			190 (75)
			W	152 (60)			142 (56)
			H	162 (64)	147 (58)		
			145 (320) ~ 154 (339)				
60.4" X 96"	RKN (LD-3) MKNF DC		3.0 (106)		See AKN	(1) Refrigerated (保冷) (2) Inside Temp: -20° ~ +20° (-4° F ~ 68° F) (3) Eff Temp: 72HRS (4) Coolant: DRY ICE 180k/396L (5) No Dry Ice Gass Inside MKNFのみ光触媒装置装着可	
			L	157 (62)			124 (49)
			L'	200 (79)			180 (71)
			W	152 (60)			124 (49)
			H	162 (64)	132 (52)		
			220 (484) ~ 265 (583)				
60.4" X 96"	MQP (LD-4)		4.9 (173)		767 LD	2449 (5400)	
			L	243 (96)			233 (92)
			W	152 (60)			139 (55)
			H	162 (64)			147 (58)
			200 (440)				
88" X 125"	RAP (LD-7)		8.2 (290)		See AAP	(1) Refrigerated (保冷) (2) Inside Temp: -20° ~ +20° (-4° F ~ 68° F) (3) Eff Temp: 72HRS (4) Coolant: DRY ICE 300k/660L (5) No Dry Ice Gass Inside	
			L	317 (125)			294 (116)
			W	223 (88)			195 (77)
			H	162 (64)			139 (55)
			438 (964)				