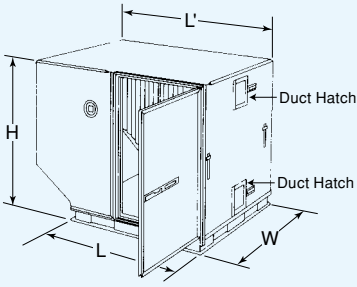
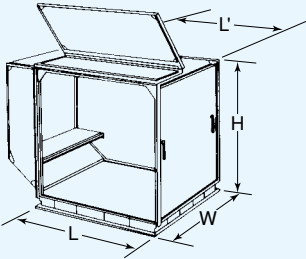
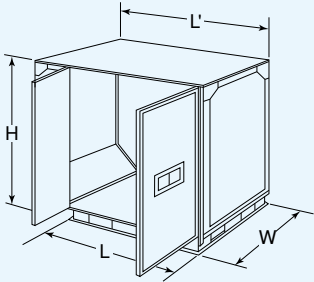
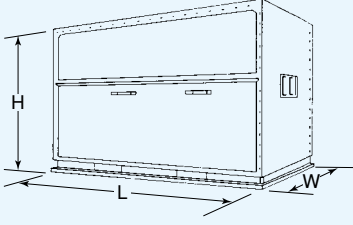
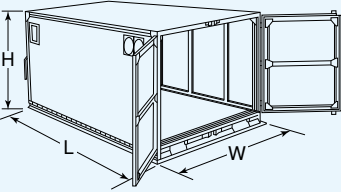

SPECIAL ULD

● 保冷コンテナ (Refrigerated ULD)

下記重量は最大値であり、搭載位置により制限がかかります。

Base Size	IATA I.D. Code (ATA Code)	Illustration イラスト	Int Volume 内容量:m ³ (ft ³)		Loadable Aircraft & Comp't 搭載可能 機種&貨物室	Weight Limitation Inc ULD Tare Wt 重量制限 含 自重 kg (lb)	
			L External Dimension 外寸 cm (in)	Internal Dimension 内寸 cm (in)			
			IC	国内 DC	Tare Wt 自重:kg (lb) *Including NET WT		Capability 性能諸元
60.4" X 61.5"	MVN (LD-3)		3.7 (131)		See DKN/DVN	(1) Thermal Insulated 保冷 (2) No Temp Control 温度管理不可 (3) Coolant: COOL AIR/DRY ICE 冷風ユニット使用	
			L	157 (62)			132 (52)
			L'	200 (79)			177 (70)
			W	152 (60)			129 (51)
60.4" X 61.5"	MKN MKNK (LD-3)		3.8 (134)		See DKN/DVN	(1) Thermal Insulated by Polystyrene panel at the inside surface 簡易保冷 (2) No Temp Control 温度管理不可	
			L	157 (62)			137 (54)
			L'	200 (79)			190 (75)
			W	152 (60)			142 (56)
60.4" X 61.5"	RKN (LD-3) MKNF DC		3.0 (106)		See AKN	(1) Refrigerated (保冷) (2) Inside Temp: -20° ~ +20° (-4° F ~ 68° F) (3) Eff Temp: 72HRS (4) Coolant: DRY ICE 180k/396L (5) No Dry Ice Gass Inside MKNFのみ光触媒装置装着可	
			L	157 (62)			124 (49)
			L'	200 (79)			180 (71)
			W	152 (60)			124 (49)
60.4" X 96"	MQP (LD-4)		4.9 (173)		767 LD 2449 (5400)	(1) Thermal Insulated by Polystyrene panel at the inside surface 簡易保冷 (2) No Temp Control 温度管理不可	
			L	243 (96)			233 (92)
			W	152 (60)			139 (55)
			H	162 (64)			147 (58)
88" X 125"	RAP (LD-7)		8.2 (290)		See AAP	(1) Refrigerated (保冷) (2) Inside Temp: -20° ~ +20° (-4° F ~ 68° F) (3) Eff Temp: 72HRS (4) Coolant: DRY ICE 300k/660L (5) No Dry Ice Gass Inside	
			L	317 (125)			294 (116)
			W	223 (88)			195 (77)
			H	162 (64)			139 (55)
			438 (964)				